

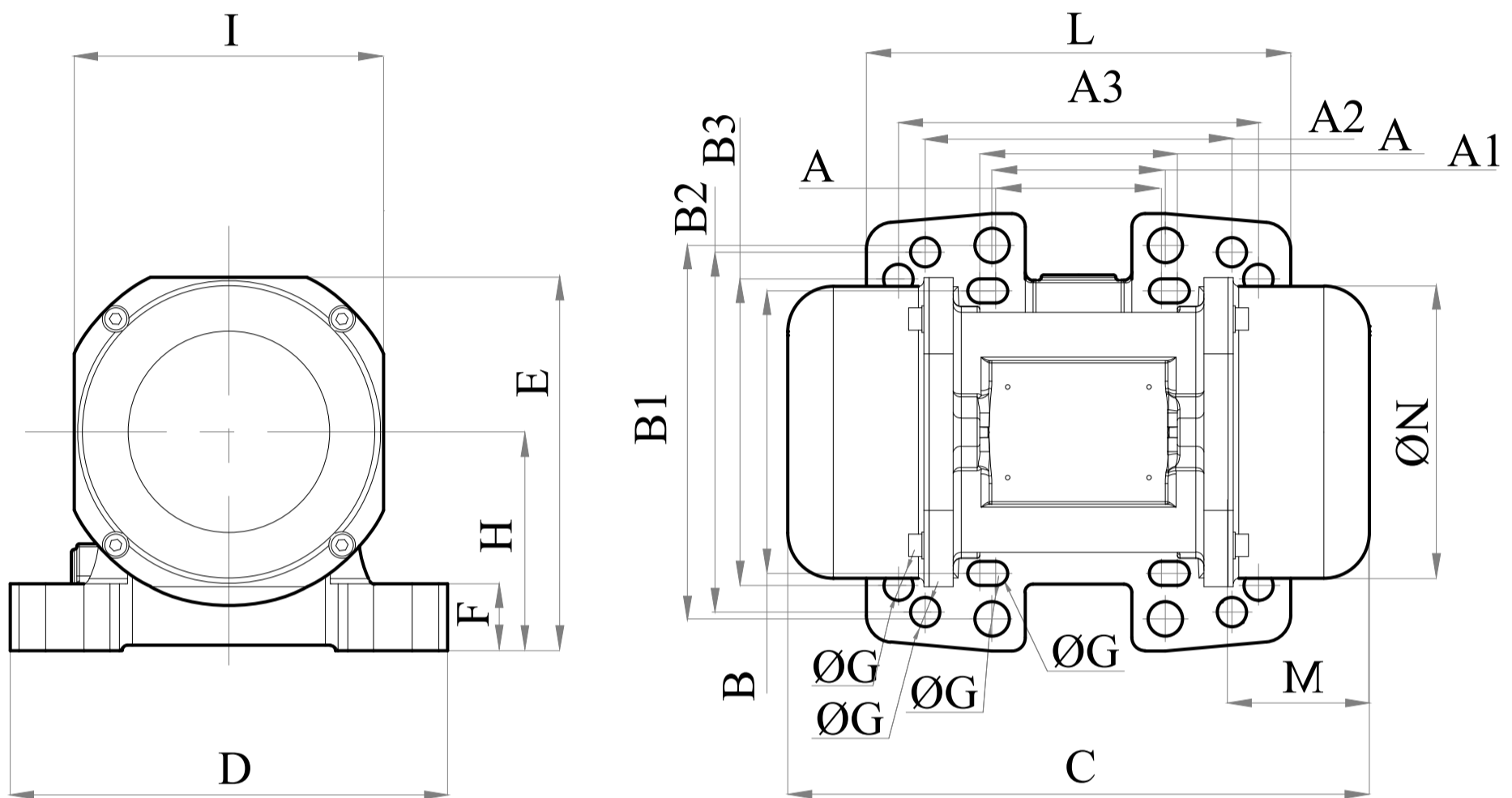

VEV 200/3E-23A0

3 PH - 2 poles - 3000 RPM - 220-240/380-415 V - 50 Hz

Working moment [Kg*cm]	Unbalance [Kg*cm]	Centrifugal force [Kg]	Nominal voltage [V]	Input power [kW]	Current [A]	Power Factor	Ia/In
3,72	1,86	187	220-240/380-415	0,15	Δ 0,61 Y 0,35	0,62	3,5



OVERALL DIMENSIONS [mm]																					
Weight [Kg]	A	A1	A2	A3	B	B1	B2	B3	G	G1	G2	Holes number	C	D	E	F	H	I	L	M	N
7,2	62-74	65	115	135	106	140	135	115	9	13	11	4	222	164	140	25	82	116	159	55	110

TECHNICAL FEATURES						
Type of grease	Greased for life	Screw	Washer	Clamping torque [Nm]	Cable type	Cable gland
/	Yes	M8-M10-M12	8,4 x 16 - 10,5 x 20 - 13 x 24 mm	23-80-45	4G2.5 80°C	M20 80°C

BEARINGS				
Bearing model	Type	Life 100%	Life 80%	Life 50%
6302 2Z		5522	10785	44176

CERTIFICATION	
ATEX II2 D Ex tb IIIC Tx Db IP66 IECEx Ex tb IIIC Tx Db IP66 CLASS II DIV.2 GROUP F,G T4 Ex tb IIIC Tx Db IP66 [Tx Size Micro,10-30:100°C - Tx Size 40-91:135°C] CONFTO UL1004-3, UL1004-1, UL 60079-0, UL60079-31 CERT. CSA C22.2 No.100, CSA C22.2 No.77, CSA C22.2N.60079-0, CSA C22.2N.60079-31 T.Amb -20/+40°C	